

CROFT, LLC

SERIES 9100 WOODBUCK MULLION AND SERIES 9100 HEAVY-DUTY MULLION (VERTICAL) (WZ3)(IMPACT)

NOTES:

- THE PRODUCT SHOWN HEREIN IS DESIGNED AND MANUFACTURED TO COMPLY WITH THE 7TH EDITION FBC, SECTION 1709.8.
- MULLION INSTALLATION DETAILS APPLY TO EXTRUDED MULLIONS WITH EXTRUDED ALUMINUM ANCHOR CLIP WHEN USED TO MULL WINDOWS SIDE BY SIDE
- APPROVED IMPACT PROTECTIVE SYSTEM IS NOT REQUIRED ON THESE PRODUCTS IN WIND BORNE DEBRIS REGIONS ZONE 3 OR LESS SUCH THAT ADJOINING WINDOWS ARE IMPACT RATED.
- APPROVED IMPACT PROTECTIVE SYSTEM IS REQUIRED ON THESE PRODUCTS IN WIND BORNE DEBRIS REGIONS ZONE 4.
- USE TWO (2) #10 WOOD SCREWS, PER CLIP, OF SUFFICIENT LENGTH TO ACHIEVE MINIMUM EMBEDMENT OF 1 1/2" INTO WOOD FRAMING. (SEE INSTALLATION DETAILS ON SHEET 2).
- USE TWO (2) 3/16" ITW TAPCONS, PER CLIP, OF SUFFICIENT LENGTH TO ACHIEVE MINIMUM EMBEDMENT OF 1 3/4" INTO CONCRETE OR 1" WHEN INTO HOLLOW BLOCK CMU. (SEE INSTALLATION DETAILS ON SHEET 2).
- USE ONE (1) 1/4" ITW TAPCON, PER CLIP, OF SUFFICIENT LENGTH TO ACHIEVE MINIMUM EMBEDMENT OF 1 3/4" WHEN ANCHORED INTO CONCRETE.
- USE TWO (2) #10-16 SELF-DRILLING SCREWS, PER CLIP, OF SUFFICIENT LENGTH TO ACHIEVE A MINIMUM 3 THREADS PENETRATION BEYOND STEEL SUBSTRATE. (SEE INSTALLATION DETAILS ON SHEET 2).
- 2X WOOD BUCKS AND STEEL STUDS TO BE DESIGNED AND ANCHORED TO PROPERLY TRANSFER ALL LOADS TO STRUCTURE AND IS THE RESPONSIBILITY OF THE ARCHITECT OR ENGINEER OF RECORD.
- SEE CHARTS & NOTES ON SHEET 3, 4, & 5 FOR DESIGN PRESSURE RATINGS.
- THIS MULLION IS ONLY VALID WHEN USED IN CONJUNCTION WITH ALL APPLICABLE CROFT, LLC PRODUCTS.
- ALL WINDOWS USED WITH THIS MULLION SHALL BE QUALIFIED UNDER SEPARATE APPROVAL. THE LESSER DESIGN PRESSURE RATING OF THE WINDOW OR THE MULLION OF INSTALLATION SHALL GOVERN THE OVERALL DESIGN PRESSURE OF THE ASSEMBLY.
- MULLION MATERIAL: 6063-T5 ALUMINUM.
- CLIP MATERIAL: 6063-T5 ALUMINUM.
- INSTALLATION ANCHOR CAPACITIES FOR PRODUCTS HEREIN ARE BASED ON SUBSTRATE MATERIALS WITH THE FOLLOWING PROPERTIES:
 - WOOD - MINIMUM SPECIFIC GRAVITY OF 0.55.
 - CONCRETE - MINIMUM COMPRESSIVE STRENGTH OF 3000 PSI.
 - CMU - SHALL CONFORM TO MINIMUM REQUIREMENTS OF ASTM C90
 - STEEL - MINIMUM YIELD STRENGTH OF 33 KSI. MINIMUM 18 GA. WALL THICKNESS.

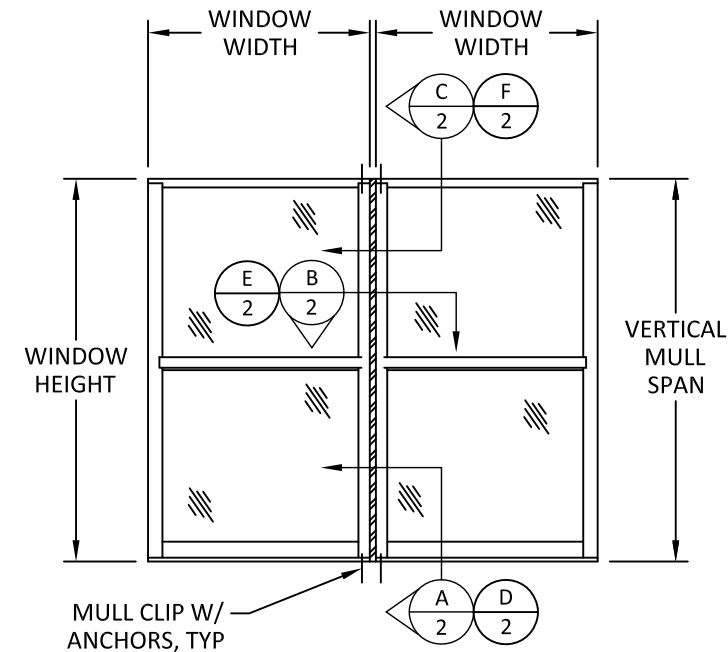

VERTICAL MULLION FOR TWIN HUNG WINDOWS

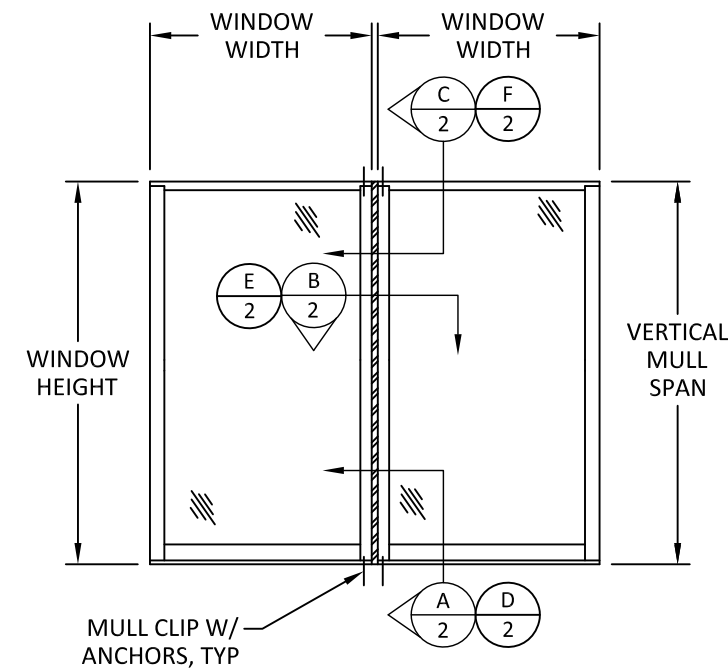

VERTICAL MULLION FOR TWIN WINDOWS

TABLE OF CONTENTS	
SHEET	SHEET DESCRIPTION
1	GENERAL NOTES & ELEVATIONS
2	MULLION INSTALLATION DETAILS & ANCHORING
3	SERIES 9100 WOODBUCK MULL DP CHART & DETAILS
4	SERIES 9100 HEAVY-DUTY MULL DP CHART & DETAIL
5	SERIES 9100 HEAVY-DUTY (LIGHT) MULL DP CHART & DETAIL



P.O. BOX 826
MCCOMB, MS 39649
PH.: 601-684-6121 FX: 601-783-3188

TITLE: SERIES 9100 VERTICAL MULLIONS (WZ3)(IMPACT)
GENERAL NOTES AND ELEVATIONS

PREPARED BY: BUILDING DROPS, INC.
398 E. DANIA BEACH BLVD., STE. 338
DANIA BEACH, FL 33004
PH: (954)399-8478
FAX: (954)744-4738
WEB: www.buildingdrops.com

REMARKS	BY	DATE
MULLS & CLIPS REV.	MTJ	6/13
FBC 2014 UPDATE	SM	9/14
FBC 2017 UPDATE	HR	6/17
FBC 2020 UPDATE	LL	6/21

THE INSTALLATION DETAILS DESCRIBED HEREIN ARE GENERIC AND MAY NOT REFLECT ACTUAL CONDITIONS FOR A SPECIFIC SITE. IF SITE CONDITIONS CAUSE INSTALLATION TO DEVIATE FROM THE REQUIREMENTS DETAILED HEREIN, A LICENSED ENGINEER OR ARCHITECT SHALL PREPARE SITE SPECIFIC DOCUMENTS FOR USE WITH THIS DOCUMENT.

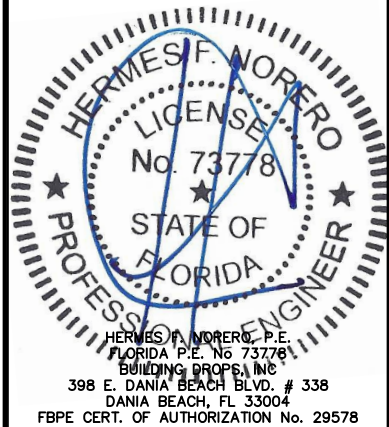

FL #: **FL15527**

DATE: **04.18.12**

DWG. BY: **MSS** CHK. BY: **HFN**

SCALE: **NTS**

DWG. #: **CRF011**

SHEET **1** OF 5



P.O. BOX 826
MCCOMB, MS 39649
PH.: 601-684-6121 FX: 601-783-3188

TITLE: **SERIES 9100 VERTICAL MULLIONS (WZ3)/(IMPACT)**
MULLION INSTALLATION DETAILS & ANCHORING

PREPARED BY: **BUILDING DROPS, INC.**
398 E. DANIA BEACH BLVD., STE. 338
DANIA BEACH, FL 33004
PH: (954)399-8478
FAX: (954)744-4738
WEB: www.buildingdrops.com

REMARKS	BY	DATE
MULLS & CLIPS REV.	MTJ	6/13
FBC 2014 UPDATE	SM	9/14
FBC 2017 UPDATE	HR	6/17
FBC 2020 UPDATE	LL	6/21

THE INSTALLATION DETAILS DESCRIBED HEREIN ARE GENERIC AND MAY NOT REFLECT ACTUAL CONDITIONS FOR A SPECIFIC SITE. IF SITE CONDITIONS CAUSE INSTALLATION TO DEVIATE FROM THE REQUIREMENTS DETAILED HEREIN, A LICENSED ENGINEER OR ARCHITECT SHALL PREPARE SITE SPECIFIC DOCUMENTS FOR USE WITH THIS DOCUMENT.

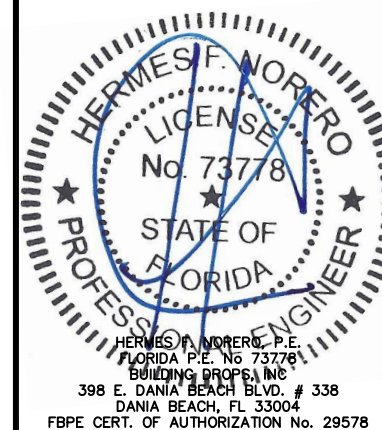

FL #: **FL15527**

DATE: **04.18.12**

DWG. BY: MSS	CHK. BY: HFN
---------------------	---------------------

SCALE: **NTS**

DWG. #: **CRF011**

SHEET

2

OF 5

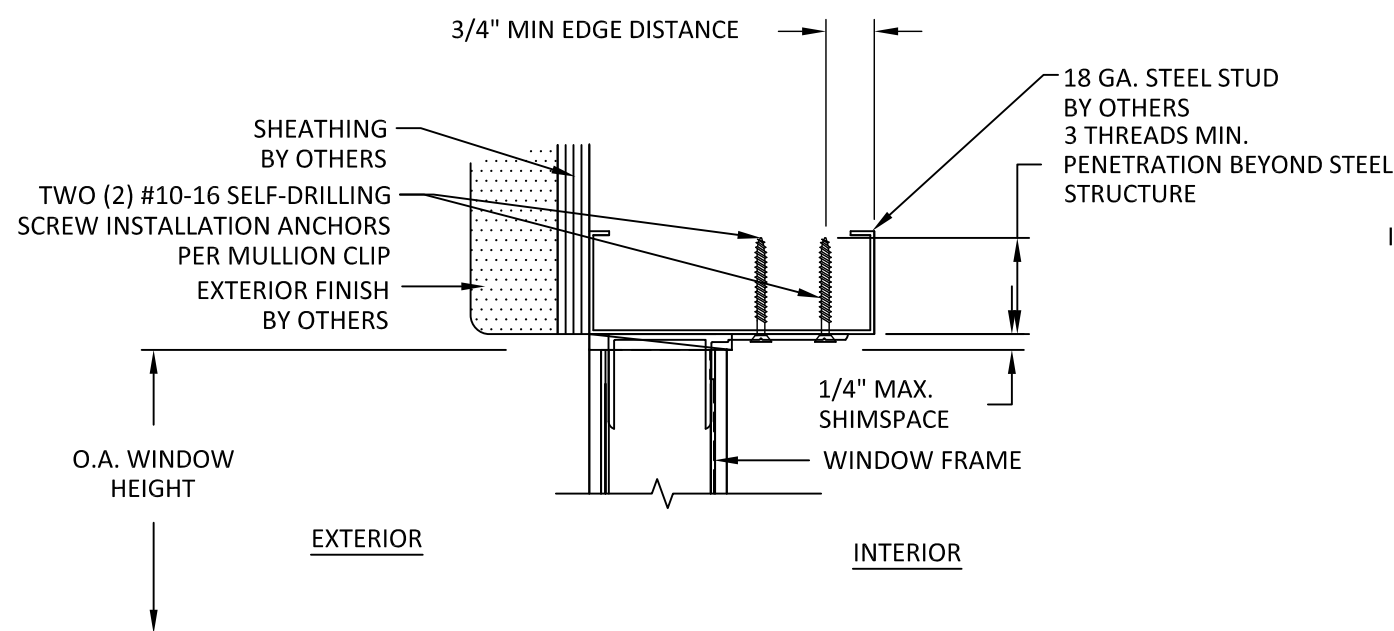

C
2 **VERTICAL SECTION**
HEAD - STEEL STUD TYP.
SERIES 9100 WOODBUCK MULL

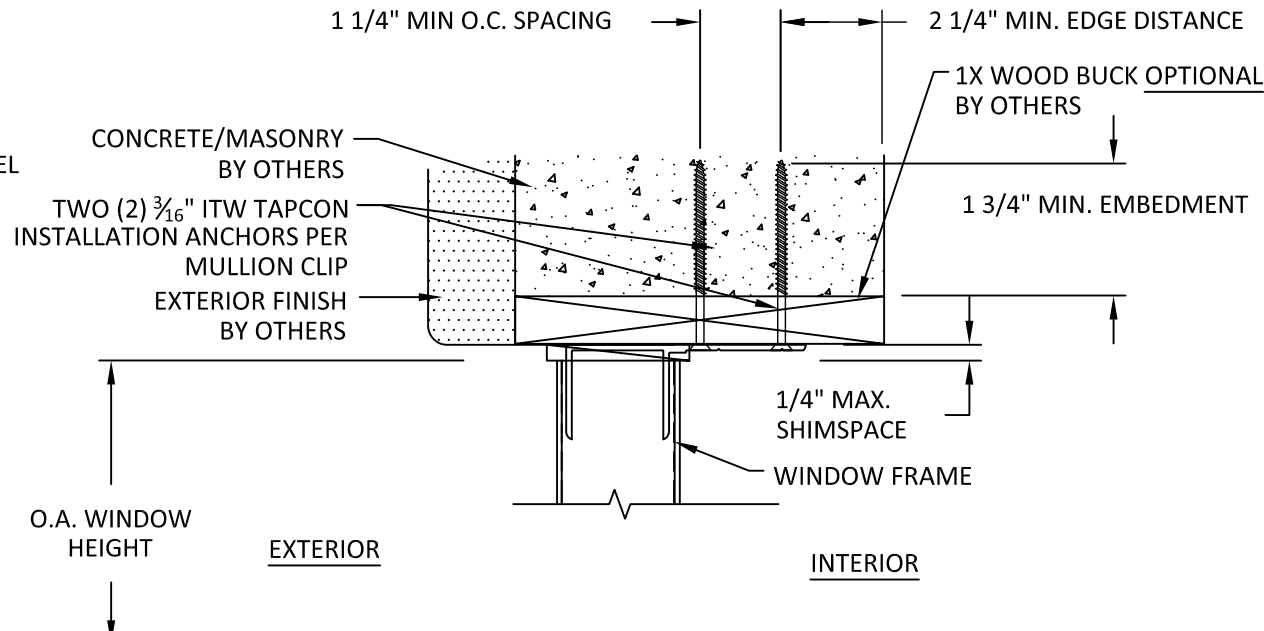

F
2 **VERTICAL SECTION**
HEAD - 1X BUCK/CONCRETE/MASONRY
SERIES 9000 MULLION (HEAVY/LIGHT)

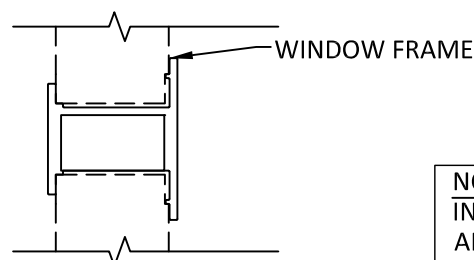

B
2 **HORIZONTAL SECTION**
SERIES 9100 WOODBUCK MULLION

NOTE:
INSTALLATION DETAILS SHOWN ARE GENERIC & ARE FOR ILLUSTRATION PURPOSES. INSTALLATION CONDITIONS SHOWN MAY BE USED WITH ANY MULLION DESCRIBED HEREIN.

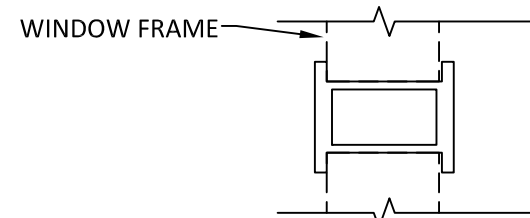

E
2 **HORIZONTAL SECTION**
SERIES 9000 MULLION (HEAVY/LIGHT)

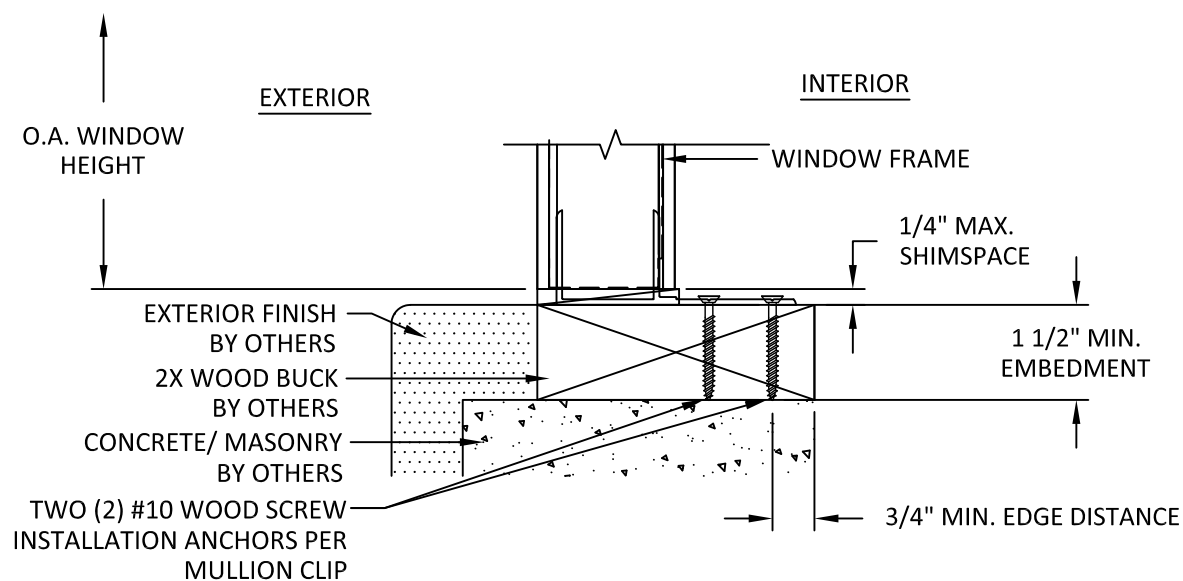

A
2 **VERTICAL SECTION**
SILL - 2X WOOD BUCK TYP.
SERIES 9100 WOODBUCK MULL

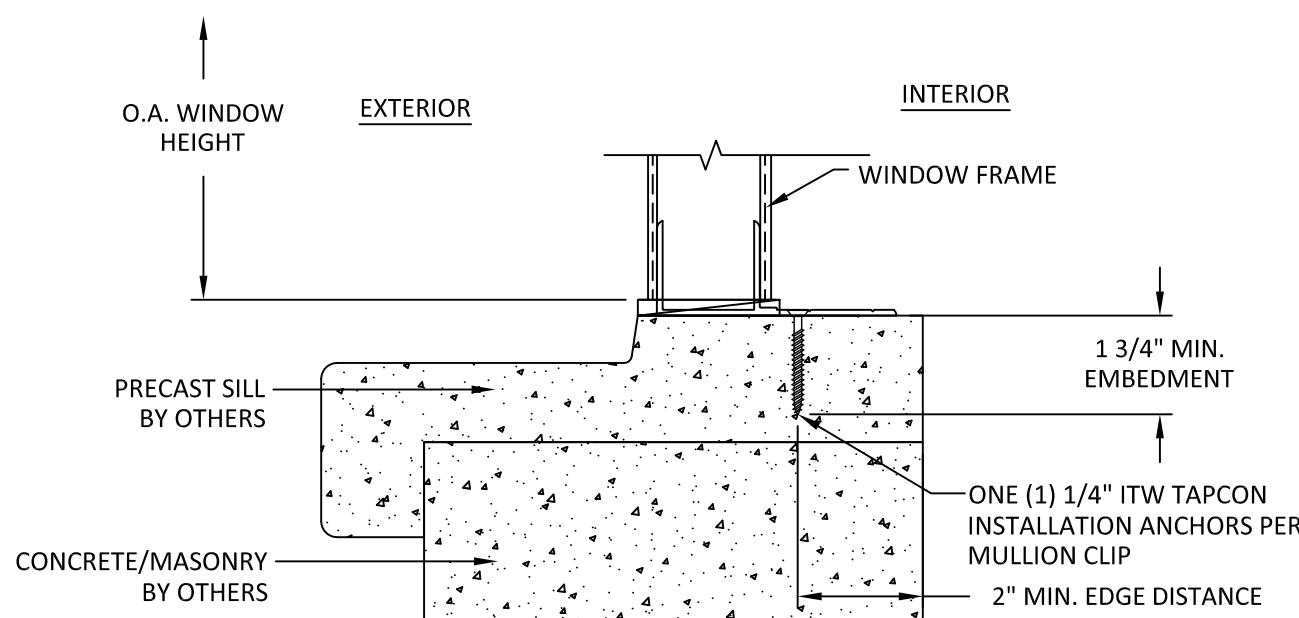

D
2 **VERTICAL SECTION**
SILL - PRECAST SILL TYP.
SERIES 9000 MULLION (HEAVY/LIGHT)

7/12/2021 9:31 AM

s:\projects\croft\lic\lbc-21-0656 - fbc submittal - revision series 9000 aluminum mullions\dwg\crf011.dwg

SERIES 9100 WOODBUCK MULL DESIGN PRESSURE CHART

Maximum design pressure capacity chart (psf)

Series 9100 Woodbuck Mullion

Design pressures are limited either by mullion or anchor screws or anchor clip capacity

Height (in)	Unit Width (in)								
	18.0	21.0	24.0	27.0	30.0	32.0	36.0	42.0	48.0
24.0	150.0	150.0	150.0	150.0	150.0	150.0	150.0	150.0	150.0
30.0	150.0	150.0	150.0	150.0	150.0	150.0	150.0	150.0	150.0
36.0	150.0	150.0	143.0	135.5	130.7	128.7	127.1	127.1	127.1
42.0	138.6	124.5	114.4	107.0	101.7	99.0	95.3	93.4	93.4
48.0	117.3	104.6	95.3	88.4	83.2	80.4	76.2	72.6	71.5
54.0	101.7	90.1	81.7	75.3	70.4	67.7	63.5	59.4	57.2
60.0	89.7	79.2	71.5	65.6	61.0	58.5	54.5	50.3	47.7
66.0	80.3	70.7	63.5	58.1	53.8	51.2	46.7	41.9	38.8
72.0	65.3	56.5	49.9	44.9	41.0	38.8	35.3	31.4	28.8
78.0	51.2	44.2	39.0	35.0	31.9	30.2	27.3	24.2	22.0
84.0	40.8	35.2	31.1	27.9	25.3	23.9	21.6	19.0	17.2
90.0	33.1	28.6	25.2	22.5	20.5	19.3	17.4	15.3	13.7
96.0	27.2	23.5	20.7	18.5	16.8	15.8	14.2	12.4	11.2

NOTES FOR SERIES 9100 WOODBUCK MULLION FOR TWIN WINDOW AND MULLION CLIP INSTALLATIONS

- THE DESIGN PRESSURES IN THIS CHART ARE FOR THE MULLIONS LISTED ABOVE WHEN USED WITH THE CLIP LISTED ABOVE.
- FOR VERTICAL MULL CLIPS IN WOOD FRAMING INSTALLATION USE TWO (2) #10 WOOD SCREWS AT EACH MULLION CLIP. ANCHORS MUST BE OF SUFFICIENT LENGTH TO ACHIEVE A 1 1/2" MINIMUM EMBEDMENT INTO FRAMING. SEE SHEET 2 FOR DETAILS.
- FOR VERTICAL MULL CLIPS IN STEEL FRAME INSTALLATION, USE (2) TWO #10-16 SELF-DRILLING SCREWS AT EACH ANCHOR CLIP WITH SUFFICIENT LENGTH TO ACHIEVE A MINIMUM 3 THREAD PENETRATION BEYOND STEEL SUBSTRATE. SEE SHEET 2 FOR DETAILS.
- FOR VERTICAL MULL CLIPS IN CONCRETE OR CMU INSTALLATION USE TWO (2) 3/16" ITW TAPCONS AT EACH MULLION CLIP. ANCHORS MUST BE OF SUFFICIENT LENGTH TO ACHIEVE A 1" MINIMUM EMBEDMENT INTO CMU (HOLLOW BLOCK) OR 1 3/4" EMBEDMENT INTO CONCRETE. SEE SHEET 2 FOR DETAILS. FOR ALTERNATE INSTALLATION TO CONCRETE, SEE NOTE 5 BELOW.
- FOR VERTICAL MULL CLIPS IN CONCRETE INSTALLATION USE ONE (1) 1/4" ITW TAPCON AT EACH MULLION CLIP. ANCHORS MUST BE OF SUFFICIENT LENGTH TO ACHIEVE A 1 3/4" EMBEDMENT INTO CONCRETE. SEE SHEET 2 FOR DETAILS.
- CHART APPLIES ONLY TO SERIES 9100 WOODBUCK MULLION AS SPECIFIED ABOVE WHEN USED TO MULL WINDOWS SIDE BY SIDE.
- READ WINDOW WIDTH AND MULL SPAN IN INCHES. DESIGN PRESSURE VALUES ON THIS CHART ARE POSITIVE AND NEGATIVE POUNDS PER SQUARE FOOT (PSF).
- DESIGN PRESSURE VALUES APPLY TO MULLION WHERE TWO OR MORE WINDOWS ARE LISTED IN A SINGLE OPENING. LESSER DESIGN PRESSURE OF INDIVIDUAL WINDOW OR MULLION OF INSTALLATION SHALL GOVERN.
- REFER TO EVALUATION REPORT# 7646 FOR MORE MULLION SPECIFICATIONS.



P.O. BOX 826
MCCOMB, MS 39649
PH.: 601-684-6121 FX: 601-783-3188

TITLE: SERIES 9100 VERTICAL MULLIONS (WZ3)/(IMPACT) SERIES 9100 WOODBUCK MULL DP CHART & DETAILS

PREPARED BY: BUILDING DROPS, INC.
398 E. DANIA BEACH BLVD., STE. 338
DANIA BEACH, FL 33004
PH: (954)399-8478
FAX: (954)744-4738
WEB: www.buildingdrops.com

REMARKS	BY	DATE
MULLS & CLIPS REV.	MTJ	6/13
FBC 2014 UPDATE	SM	9/14
FBC 2017 UPDATE	HR	6/17
FBC 2020 UPDATE	LL	6/21

THE INSTALLATION DETAILS DESCRIBED HEREIN ARE GENERIC AND MAY NOT REFLECT ACTUAL CONDITIONS FOR A SPECIFIC SITE. IF SITE CONDITIONS CAUSE INSTALLATION TO DEVIATE FROM THE REQUIREMENTS DETAILED HEREIN, A LICENSED ENGINEER OR ARCHITECT SHALL PREPARE SITE SPECIFIC DOCUMENTS FOR USE WITH THIS DOCUMENT.

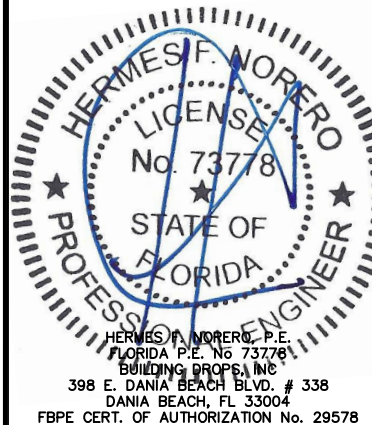

FL #:

FL15527

DATE: **04.18.12**

DWG. BY: **MSS** CHK. BY: **HFN**

SCALE: **NTS**

DWG. #: **CRF011**

SHEET

3

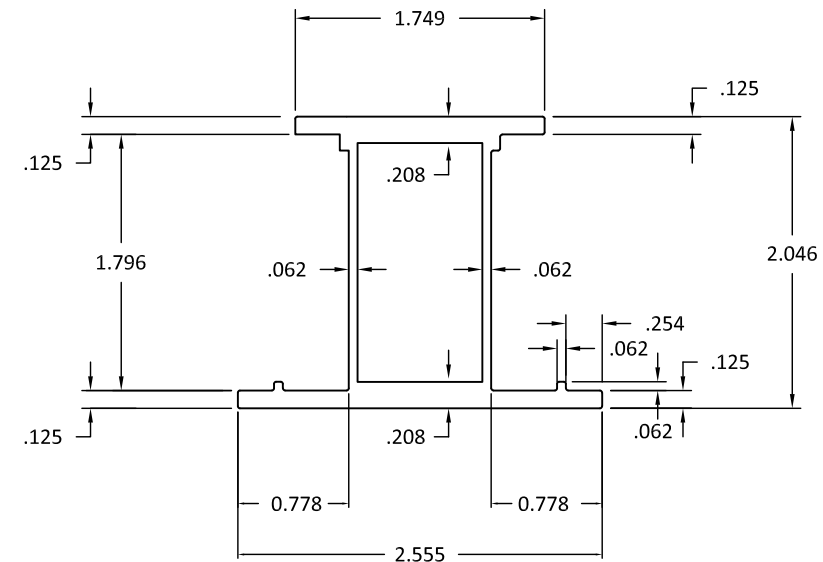

SERIES 9100 WOODBUCK MULL DETAIL

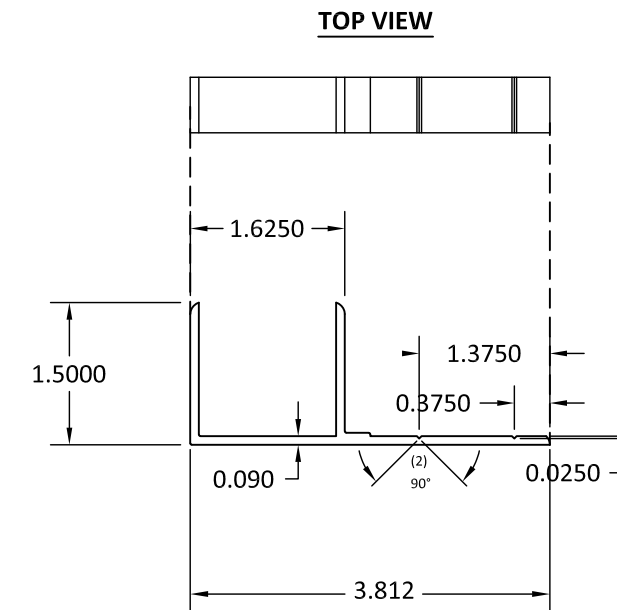

SERIES 9000 MULLION CLIP DETAIL

FOR USE WITH ALL SERIES 9000 MULLIONS

SERIES 9100 MULLION-HEAVY DUTY DESIGN PRESSURE CHART

Maximum design pressure capacity chart (psf)

Series 9100 Heavy Duty Mullion

Design pressures are limited either by mullion or anchor screws or anchor clip capacity

Height (in)	Unit Width (in)								
	18.0	21.0	24.0	27.0	30.0	32.0	36.0	42.0	48.0
24.0	150.0	150.0	150.0	150.0	150.0	150.0	150.0	150.0	150.0
30.0	150.0	150.0	150.0	150.0	150.0	150.0	150.0	150.0	150.0
36.0	150.0	150.0	143.0	135.5	130.7	128.7	127.1	127.1	127.1
42.0	138.6	124.5	114.4	107.0	101.7	99.0	95.3	93.4	93.4
48.0	117.3	104.6	95.3	88.4	83.2	80.4	76.2	72.6	71.5
54.0	101.7	90.1	81.7	75.3	70.4	67.7	63.5	59.4	57.2
60.0	89.7	79.2	71.5	65.6	61.0	58.5	53.5	48.2	44.9
66.0	79.7	69.0	61.0	54.9	50.1	47.5	43.2	38.5	35.4
72.0	66.7	57.6	50.9	45.7	41.6	39.3	35.6	31.6	28.8
78.0	56.7	48.9	43.1	38.7	35.1	33.2	30.0	26.4	23.9
84.0	48.8	42.0	37.0	33.1	30.1	28.4	25.6	22.4	20.2
90.0	42.4	36.5	32.1	28.7	26.1	24.6	22.1	19.3	17.3
96.0	36.5	31.5	27.7	24.8	22.5	21.2	19.1	16.7	15.0

NOTES FOR SERIES 9100 HEAVY-DUTY MULLION FOR TWIN WINDOW AND MULLION CLIP INSTALLATIONS

1. THE DESIGN PRESSURES IN THIS CHART ARE FOR THE MULLIONS LISTED ABOVE WHEN USED WITH THE CLIP LISTED ABOVE.
2. FOR VERTICAL MULL CLIPS IN WOOD FRAMING INSTALLATION USE TWO (2) #10 WOOD SCREWS AT EACH MULLION CLIP. ANCHORS MUST BE OF SUFFICIENT LENGTH TO ACHIEVE A 1 1/2" MINIMUM EMBEDMENT INTO FRAMING. SEE SHEET 2 FOR DETAILS.
3. FOR VERTICAL MULL CLIPS IN STEEL FRAME INSTALLATION, USE (2) TWO #10-16 SELF-DRILLING SCREWS AT EACH ANCHOR CLIP WITH SUFFICIENT LENGTH TO ACHIEVE A MINIMUM 3 THREAD PENETRATION BEYOND STEEL SUBSTRATE. SEE SHEET 2 FOR DETAILS.
4. FOR VERTICAL MULL CLIPS IN CONCRETE OR CMU INSTALLATION USE TWO (2) 3/16" ITW TAPCONS AT EACH MULLION CLIP. ANCHORS MUST BE OF SUFFICIENT LENGTH TO ACHIEVE A 1" MINIMUM EMBEDMENT INTO CMU (HOLLOW BLOCK) OR 1 3/4" EMBEDMENT INTO CONCRETE. SEE SHEET 2 FOR DETAILS. FOR ALTERNATE INSTALLATION TO CONCRETE, SEE NOTE 5 BELOW.
5. FOR VERTICAL MULL CLIPS IN CONCRETE INSTALLATION USE ONE (1) 1/4" ITW TAPCON AT EACH MULLION CLIP. ANCHORS MUST BE OF SUFFICIENT LENGTH TO ACHIEVE A 1 3/4" EMBEDMENT INTO CONCRETE. SEE SHEET 2 FOR DETAILS.
6. CHART APPLIES ONLY TO SERIES 9100 HEAVY DUTY MULLION AS SPECIFIED ABOVE WHEN USED TO MULL WINDOWS SIDE BY SIDE.
7. READ WINDOW WIDTH AND MULL SPAN IN INCHES. DESIGN PRESSURE VALUES ON THIS CHART ARE POSITIVE AND NEGATIVE POUNDS PER SQUARE FOOT (PSF).
8. DESIGN PRESSURE VALUES APPLY TO MULLION WHERE TWO OR MORE WINDOWS ARE LISTED IN A SINGLE OPENING. LESSER DESIGN PRESSURE OF INDIVIDUAL WINDOW OR MULLION OF INSTALLATION SHALL GOVERN.
9. REFER TO EVALUATION REPORT# 7646 FOR MORE MULLION SPECIFICATIONS.

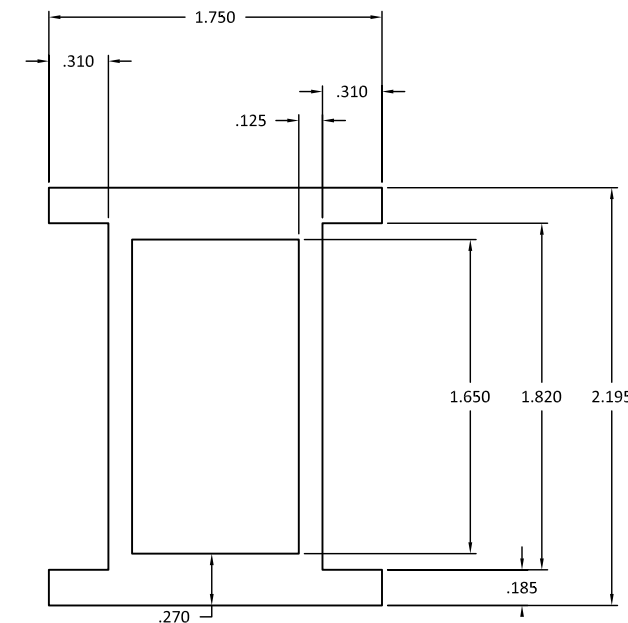

SERIES 9100 MULLION-HEAVY DUTY DETAIL



P.O. BOX 826
MCCOMB, MS 39649
PH.: 601-684-6121 FX: 601-783-3188

TITLE: SERIES 9100 VERTICAL MULLIONS (WZ3)/(IMPACT)
SERIES 9100 HEAVY-DUTY MULL DP CHART & DETAIL

PREPARED BY: BUILDING DROPS, INC.
398 E. DANIA BEACH BLVD., STE. 338
DANIA BEACH, FL 33004
PH: (954)399-8478
FAX: (954)744-4738
WEB: www.buildingdrops.com

REMARKS	BY	DATE
MULLS & CLIPS REV.	MTJ	6/13
FBC 2014 UPDATE	SM	9/14
FBC 2017 UPDATE	HR	6/17
FBC 2020 UPDATE	LL	6/21

THE INSTALLATION DETAILS DESCRIBED HEREIN ARE GENERIC AND MAY NOT REFLECT ACTUAL CONDITIONS FOR A SPECIFIC SITE. IF SITE CONDITIONS CAUSE INSTALLATION TO DEVIATE FROM THE REQUIREMENTS DETAILED HEREIN, A LICENSED ENGINEER OR ARCHITECT SHALL PREPARE SITE SPECIFIC DOCUMENTS FOR USE WITH THIS DOCUMENT.

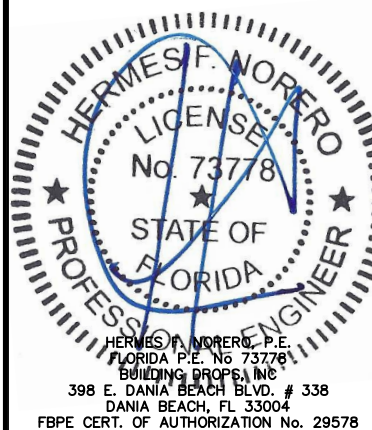

FL #:
FL15527

DATE: **04.18.12**

DWG. BY: **MSS** CHK. BY: **HFN**

SCALE: **NTS**

DWG. #: **CRF011**

SHEET
4

7/12/2021 9:31 AM

SERIES 9100 MULLION-HEAVY DUTY (LIGHT) DESIGN PRESSURE CHART

Maximum design pressure capacity chart (psf)

Series 9100 Heavy Duty (Light) Mullion

Design pressures are limited either by mullion or anchor screws or anchor clip capacity

Height (in)	Unit Width (in)								
	18.0	21.0	24.0	27.0	30.0	32.0	36.0	42.0	48.0
24.0	150.0	150.0	150.0	150.0	150.0	150.0	150.0	150.0	150.0
30.0	150.0	150.0	150.0	150.0	150.0	150.0	150.0	150.0	150.0
36.0	150.0	150.0	137.2	127.8	121.6	119.0	116.8	116.8	116.8
42.0	121.9	107.0	96.3	88.5	82.8	79.8	75.8	73.6	73.6
48.0	91.9	80.2	71.7	65.3	60.5	57.9	53.9	50.4	49.3
54.0	71.9	62.5	55.6	50.4	46.3	44.1	40.6	37.2	35.2
60.0	57.8	50.1	44.4	40.1	36.7	34.9	31.9	28.7	26.7
66.0	47.5	41.1	36.4	32.7	29.9	28.3	25.7	23.0	21.1
72.0	39.8	34.4	30.3	27.2	24.8	23.5	21.2	18.8	17.1
78.0	33.8	29.2	25.7	23.0	20.9	19.8	17.9	15.7	14.2
84.0	29.1	25.0	22.1	19.8	17.9	16.9	15.2	13.4	12.0
90.0	25.0	21.5	19.0	17.0	15.4	14.5	13.1	11.5	10.3
96.0	20.5	17.7	15.6	13.9	12.6	11.9	10.7	9.4	8.4

NOTES FOR SERIES 9100 HEAVY-DUTY (LIGHT) MULLION FOR TWIN WINDOW AND MULLION CLIP INSTALLATIONS

- THE DESIGN PRESSURES IN THIS CHART ARE FOR THE MULLIONS LISTED ABOVE WHEN USED WITH THE CLIP LISTED ABOVE.
- FOR VERTICAL MULL CLIPS IN WOOD FRAMING INSTALLATION USE TWO (2) #10 WOOD SCREWS AT EACH MULLION CLIP. ANCHORS MUST BE OF SUFFICIENT LENGTH TO ACHIEVE A 1 1/2" MINIMUM EMBEDMENT INTO FRAMING. SEE SHEET 2 FOR DETAILS.
- FOR VERTICAL MULL CLIPS IN STEEL FRAME INSTALLATION, USE (2) TWO #10-16 SELF-DRILLING SCREWS AT EACH ANCHOR CLIP WITH SUFFICIENT LENGTH TO ACHIEVE A MINIMUM 3 THREAD PENETRATION BEYOND STEEL SUBSTRATE. SEE SHEET 2 FOR DETAILS.
- FOR VERTICAL MULL CLIPS IN CONCRETE OR CMU INSTALLATION USE TWO (2) 3/16" ITW TAPCONS AT EACH MULLION CLIP. ANCHORS MUST BE OF SUFFICIENT LENGTH TO ACHIEVE A 1" MINIMUM EMBEDMENT INTO CMU (HOLLOW BLOCK) OR 1 3/4" EMBEDMENT INTO CONCRETE. SEE SHEET 2 FOR DETAILS. FOR ALTERNATE INSTALLATION TO CONCRETE, SEE NOTE 5 BELOW.
- FOR VERTICAL MULL CLIPS IN CONCRETE INSTALLATION USE ONE (1) 1/4" ITW TAPCON AT EACH MULLION CLIP. ANCHORS MUST BE OF SUFFICIENT LENGTH TO ACHIEVE A 1 3/4" EMBEDMENT INTO CONCRETE. SEE SHEET 2 FOR DETAILS.
- CHART APPLIES ONLY TO SERIES 9100 HEAVY DUTY MULLION (LIGHT) AS SPECIFIED ABOVE WHEN USED TO MULL WINDOWS SIDE BY SIDE.
- READ WINDOW WIDTH AND MULL SPAN IN INCHES. DESIGN PRESSURE VALUES ON THIS CHART ARE POSITIVE AND NEGATIVE POUNDS PER SQUARE FOOT (PSF).
- DESIGN PRESSURE VALUES APPLY TO MULLION WHERE TWO OR MORE WINDOWS ARE LISTED IN A SINGLE OPENING. LESSER DESIGN PRESSURE OF INDIVIDUAL WINDOW OR MULLION OF INSTALLATION SHALL GOVERN.
- REFER TO EVALUATION REPORT# 7646 FOR MORE MULLION SPECIFICATIONS.

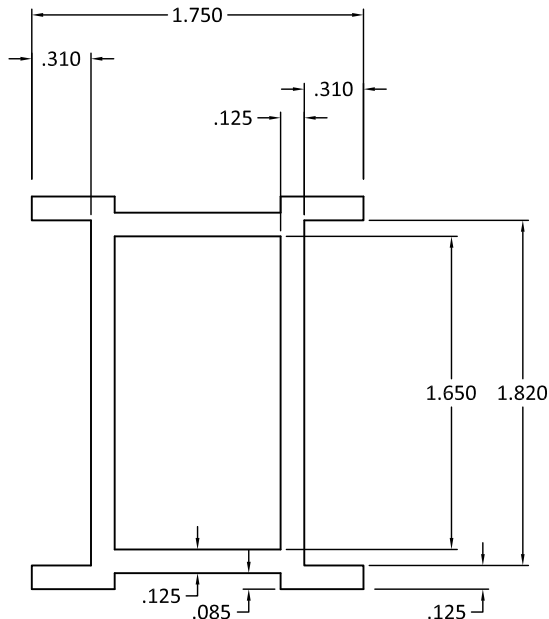

SERIES 9100 MULLION-HEAVY DUTY (LIGHT) DETAIL



P.O. BOX 826
MCCOMB, MS 39649
PH.: 601-684-6121 FX: 601-783-3188

TITLE: SERIES 9100 VERTICAL MULLIONS (WZ3)/(IMPACT) SERIES 9100 HEAVY-DUTY (LIGHT) MULL DP CHART & DETAIL

PREPARED BY: BUILDING DROPS, INC.
398 E. DANIA BEACH BLVD., STE. 338
DANIA BEACH, FL 33004
PH: (954)399-8478
FAX: (954)744-4738
WEB: www.buildingdrops.com

REMARKS	BY	DATE
MULLS & CLIPS REV.	MTJ	6/13
FBC 2014 UPDATE	SM	9/14
FBC 2017 UPDATE	HR	6/17
FBC 2020 UPDATE	LL	6/21

THE INSTALLATION DETAILS DESCRIBED HEREIN ARE GENERIC AND MAY NOT REFLECT ACTUAL CONDITIONS FOR A SPECIFIC SITE. IF SITE CONDITIONS CAUSE INSTALLATION TO DEVIATE FROM THE REQUIREMENTS DETAILED HEREIN, A LICENSED ENGINEER OR ARCHITECT SHALL PREPARE SITE SPECIFIC DOCUMENTS FOR USE WITH THIS DOCUMENT.

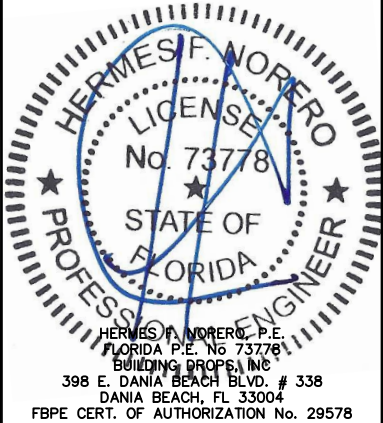

FL #:	FL15527
DATE:	04.18.12
DWG. BY:	MSS
CHK. BY:	HFN
SCALE:	NTS
DWG. #:	CRF011
SHEET	5

s:\projects\croft lic fbc-21-0656 - fbc submittal - revision series 9100 aluminum mullions\dwg\crf011.dwg